

BOUNDARY SURVEY OF
912 CAPITOL LANDING ROAD
 BEING TAX PARCEL NO. 408-0A-00-032

CITY OF WILLIAMSBURG VIRGINIA
 DATE: 04/02/2015 SCALE: 1"=30' JOB # 15-083

LRI
LANDTECH
RESOURCES, INC.
 ENGINEERING • SURVEYING • GPS

3925 Midlands Road Williamsburg, VA 23188
 Ph: (757) 565-1677 Fax: (757) 565-0782
 web: landtechresources.com



RECORD
 MERIDIAN
 PLAT RECORDED IN YORK CO.
 D.B. 122, PG. 316

LEGEND

- CB CATCH BASIN
- TELEPHONE PEDESTAL
- ⊙ TELEPHONE MANHOLE
- ⊞ WATER METER
- ⊞ WATER VAULT
- HW CONC. HEADWALL
- ⊙ SEWER CLEAN OUT
- OH— OVERHEAD UTILITIES
- ⊙ UTILITY POLE
- ⊙ GUY ANCHOR
- ⊙ LIGHT POLE
- ⊙ SANITARY SEWER MANHOLE
- ▒ CONCRETE

IRF = IRON ROD FOUND
 CMF = CONCRETE MONUMENT FOUND
 IPF = IRON PIPE FOUND
 IRS = IRON ROD SET

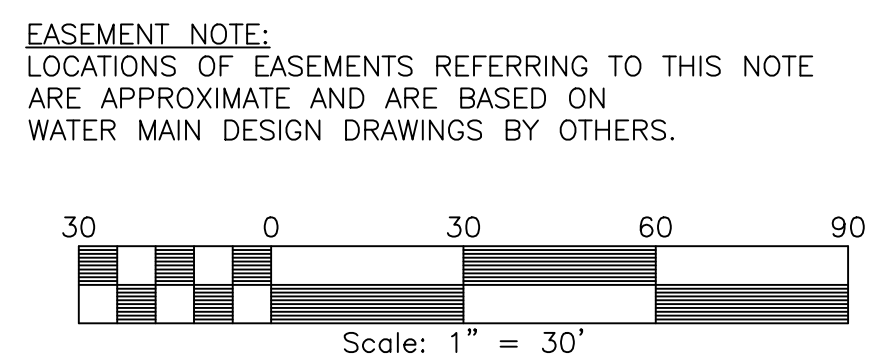

N/F
 CHARLES CITY TIMBER AND MATERIALS CO.
 INST. #132105
 D.B. 65, PG. 21 (PLAT)

BRYHN LIMITED PARTNERSHIP
 INST. #010323
 P.B. 4, PG. 154 (YORK CO.)
 PARCEL NO. 408-0A-00-032
 #912 CAPITOL LANDING ROAD
 116,244 S.F.
 2.6686 AC.

N/F
 COLONIAL PINES
 APARTMENTS, LLC
 INST. #980209

N/F
 KEENE PROPERTIES, INC.
 D.B. 50, PG. 461
 D.B. 122, PG. 316 (PLAT) (YORK CO.)

- NOTES:**
1. THIS PLAT WAS PRODUCED WITHOUT THE BENEFIT OF A TITLE REPORT AND, UNLESS NOTED, REFLECTS ONLY THOSE ENCUMBRANCES, EASEMENTS AND SETBACKS AS SHOWN IN YORK CO D.B. 122, PG. 316.
 2. THIS FIRM IS NOT RESPONSIBLE FOR THE LOCATION OF ANY STRUCTURE, MANHOLE, VALVE, ETC., HIDDEN OR OBSTRUCTED AT THE TIME THE FIELD SURVEY WAS PERFORMED.
 3. LOT LIES IN F.I.R.M. ZONE "X" ACCORDING TO FLOOD INSURANCE RATE MAP #51095C0145C, DATED SEPTEMBER 28, 2007.
 4. RESOURCE PROTECTION AREAS & WETLANDS, IF ANY, WERE NOT LOCATED FOR THIS SURVEY.
 5. UNDERGROUND UTILITIES WERE NOT LOCATED.
 6. THIS LAND BOUNDARY SURVEY IS BASED ON A CURRENT FIELD SURVEY COMPLETED 4/01/2015.
 7. THE RECORDED PLAT FOR THIS PROPERTY (YORK CO. P.B. 4, PG. 154) DOES NOT MATHEMATICALLY CLOSE. BOUNDARY SHOWN HEREON IS BASED ON RECORDED PLATS AND MONUMENTATION FOUND. BEARING BASE HELD IS FROM PLAT OF ADJOINING PROPERTY TO THE NORTH SURVEYED IN CONJUNCTION WITH PROPERTY SHOWN HEREON.

CURRENT OWNER: BRYHN LIMITED PARTNERSHIP
 INST. #010319
 PROPERTY ADDRESS: 912 CAPITOL LANDING ROAD
 WILLIAMSBURG, VA 23185

